



Efficiency Pac®

**High Efficiency
Commercial Gas
Water Heaters**

The "Smartest Idea" in Commercial Water Heating

When you depend on hot water to stay in business, you should expect your water heater to work "smarter," not harder! Traditional tank-type water heaters build up lime scale deposits when they heat water. This makes the water heater work harder, which leads to reduced efficiency, increased fuel costs, and shorter tank life. Lime scale build-up can cause a typical tank-type unit to fail in as few as 4–5 years. Sometimes less!

The Efficiency Pac from Lochinvar combines the high efficiency of an Efficiency+ (EW series) water heater with the durability of a Lock-Temp baffled storage tank to create a water heating system that performs at peak efficiency year after year.

- **Thermal Efficiency** – the Efficiency Pac delivers a remarkable 85% thermal efficiency. Most tank-type units peak at 80%.
- **No Lime Scale Build-up** – the Efficiency Pac limits lime scale build-up with the scrubbing action of water flow through the solid copper-tube heat exchanger.
- **Unsurpassed Delivery** – the Lock-Temp storage tank employs a baffle that allows 80% tank draw down without a drop in temperature. When combined with an 85% efficient water heater, the results are a First Hour Delivery that can't be beat - 274 gallons for an EPN200-85.
- **Direct-Venting Convenience** – The Efficiency Pac can draw its combustion air directly from outdoors. This feature prevents contamination from airborne dirt particles and chemicals, while isolating the water heater from negative air pressures often found in restaurants and mechanical rooms.
- **Warranty** – 3 year limited warranty on heat exchanger. 5 year limited warranty on tank.



Fuel Savings Chart*

Gallons per Day Water Usage	Btu required @75% Thermal Efficiency	Btu required @85% Thermal Efficiency	Btu Savings Per Day	Yearly Fuel Savings	Fuel Savings Over 5 Years
500	550,000	485,294	64,706	\$201	\$1,004
750	825,000	727,941	97,059	\$301	\$1,506
1,500	1,650,000	1,455,882	194,118	\$602	\$3,011
3,000	3,300,000	2,911,765	388,235	\$1,205	\$6,022
5,000	5,500,000	4,852,941	647,059	\$2,008	\$10,038

*Calculated at \$0.85 per therm with a 100°F temperature rise.

Venting Options

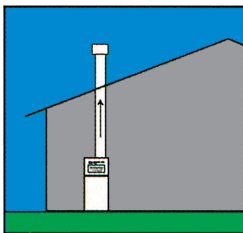

Conventional
Vents into conventional flue or vent breaching using type B double wall vent.

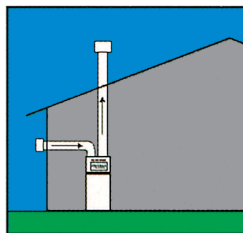

E+ DirectAire Vent**
Draws fresh combustion air from outside and vents combustion by-products through a vertical flue.

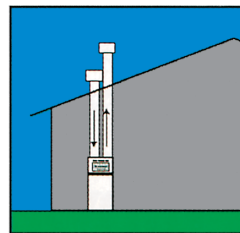

Direct Vent Vertical
Draws fresh combustion air from outside, and vents combustion by-products through a vertical flue.

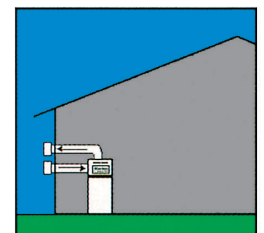

*** Direct Vent Horizontal**
Draws fresh combustion air from outside, and vents combustion by-products through a side wall.

** Requires factory supplied vent kit.

Efficiency Pac® Water Heater Dimensions & Specifications

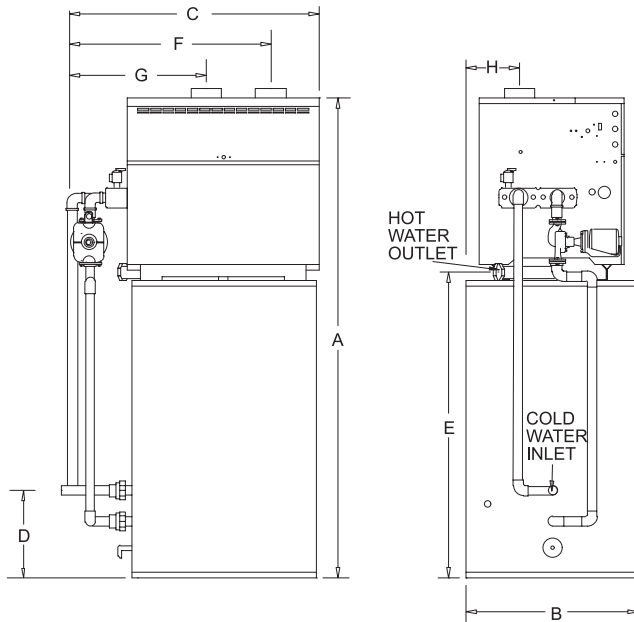

FOR EASE IN ORDERING
By Model Number

EP	N	150	85
Model	Fuel Type	Btu/hr Input	Tank Capacity

This heater is a 150,000 Btu/hr natural gas Efficiency Pac water heater with an 85 gallon storage tank.

Model Number	Btu/hr Input	Gallon Capacity	GPH @ 100°F Rise	A	B	C	D	E	F	G	H	Vent Size	Shipping Weight
EPN150-085	150,000	85	155	78-1/2"	28"	40"	14-1/2"	50-1/4"	30-1/2"	21-3/4"	9"	5"	735
EPN200-085	199,999	85	206	78-1/2"	28"	40"	14-1/2"	50-1/4"	34-1/2"	23-3/4"	9"	5"	770
EPN200-100	199,999	100	206	75"	32"	44"	16-1/2"	47"	34-1/2"	23-3/4"	11"	5"	895
EPN250-100	250,000	100	258	75"	32"	44"	16-1/2"	47"	38-1/4"	25-1/2"	11"	6"	895
EPN300-100	300,000	100	309	75"	32"	45-3/4"	16-1/2"	47"	42"	27-1/2"	11"	6"	930

Note: Change 'N' to 'L' for LP gas models. (no deration for LP).

Air inlet dimensions equal vent diameter.

Vent size denotes conventional vent.

Performance data is based on manufacturer test results.

Cold water inlet is 2" copper.

Hot water outlet is 1-1/2" copper.

Gas connections are 3/4" NPT.

Note: Agency certification applies to EW water heater.

Standard Features

- 85% Thermal Efficiency
- Sealed Combustion Chamber
- Stainless Steel Burners
- Low NOx Operation Exceeds the most Stringent Air Quality Requirements
- ASME Copper Finned Tube Heat Exchanger
- 160 psi Working Pressure
- Gasketless Heat Exchanger Design
- All Bronze Circulating Pump
- Pump Delay w/ Freeze Protection
- Manual Reset High Limit
- Automatic Reset High Limit
- Glass-Lined Water Surfaces
- Loch-Heat Ceramic Tile Combustion Chamber
- Hot Surface Ignition
- ASME Pressure Relief Valve (Heater)
- R16 Foam Insulated, Glass-Lined Storage Tank
- 24 Volt Control System
- ASME Temperature & Pressure Relief Valve (Tank)
- Brass Drain Valve (Tank)
- 3 Year Limited Warranty on Heat Exchanger
- 5 Year Limited Warranty on Tank

Optional Equipment

- Adjustable High Limit w/ Manual Reset
- Alarm Bell
- Contacts on any Failure
- Cupro-Nickel Heat Exchanger
- Flow Switch
- Low Water Cut-Off

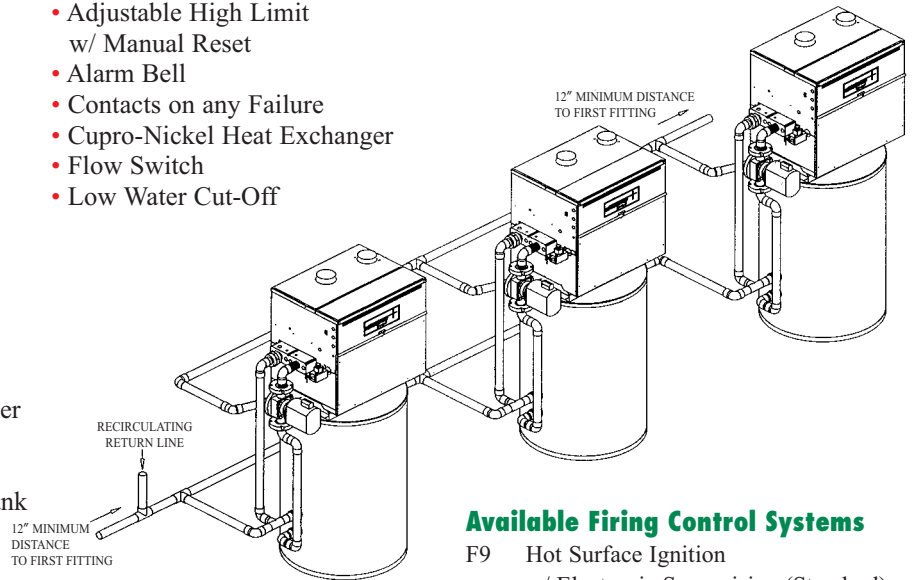

Available Firing Control Systems

- F9 Hot Surface Ignition w/ Electronic Supervision (Standard)
- F7 California Code

US and Foreign Patents 5,989,020



Lochinvar
High Efficiency Water Heaters, Boilers and Pool Heaters



Lochinvar Corporation • 300 Maddox Simpson Pkwy • Lebanon, TN 37090 • 615-889-8900 / Fax: 615-547-1000

www.Lochinvar.com