

HIGH EFFICIENCY COMMERCIAL CONDENSING BOILERS



SMART SYSTEM™

OPERATING CONTROL FEATURING
A BUILT-IN CASCADING SEQUENCER

5 MODELS: 399,000 – 800,000 BTU/HR

FIRING RATE MODULATION TO 5:1

LESS THAN 30 ppm NOx

DIRECT-VENT FLEXIBILITY TO 100 FEET



**UP TO 94.6%
THERMAL EFFICIENCY**



lochinvar.com



THE SMARTEST CHOICE FOR CONDENSING BOILER PERFORMANCE

The KNIGHT® XL, engineered with Lochinvar's exclusive SMART SYSTEM™ control and an array of other innovative features, places it far ahead of any commercial heating boiler in its class. It promises and delivers ultimate ease of installation and maintenance. With up to 94.6% thermal efficiency, low-NOx emissions and a fully modulating burner, it is the best "green choice" for today's environmentally focused market.

Five modulating/condensing stainless steel KNIGHT XL boilers are available, with 399,000–800,000 Btu/hr inputs, with remarkably small space-saving footprints. All are equipped for direct-vent installation with air intake and exhaust runs up to 100 feet using PVC, CPVC or AL29-4C venting materials. This range of choices is ideal for light-duty applications such as small hotels, schools and office buildings. For higher-demand applications, up to eight KNIGHT XL units can be installed utilizing the built-in cascading sequencer to deliver up to 6.4 million Btu/hr heating capacity.

THE KNIGHT XL BOILER reflects Lochinvar's constant commitment to providing all the options you need to serve every application.

THE KNIGHT XL COMBUSTION SYSTEM

ADVANCED NEGATIVE REGULATION TECHNOLOGY

KNIGHT XL safely and reliably operates with supply gas pressure as low as 4 inches water column, as Negative Regulation (Neg/Reg) technology automatically adjusts fan speed that ensures the correct volume and mix of fuel and air throughout the firing range.

"FAIL-SAFE" DIRECT-SPARK IGNITION

With each call for heat, two electrodes ignite the fuel/gas mixture. A third electrode then senses for flame. SMART SYSTEM will lock out and display the fault if ignition does not occur.

TWO-IN-ONE STAINLESS STEEL HEAT EXCHANGER

A combined primary and secondary heat exchanger captures flue gas heat and allows entering water temperatures as low as 50°F. The stainless steel, pH-tolerant design features a weld-sealed assembly with no O-rings or gaskets, and does not require special glycol. ASME Section IV approved and stamped.

FULLY MODULATING BURNER

The SMART SYSTEM allows fully modulating combustion with 5:1 turndown. The burner can fire as low as 20% of maximum input, and modulates the firing rate up to 100% as demand increases. The burner is a single stainless steel assembly covered with woven steel mesh, and fires in a 360° pattern along the entire length of the primary heat exchanger. This allows the compact KNIGHT XL to exceed the capacity of units with larger multiple burners.

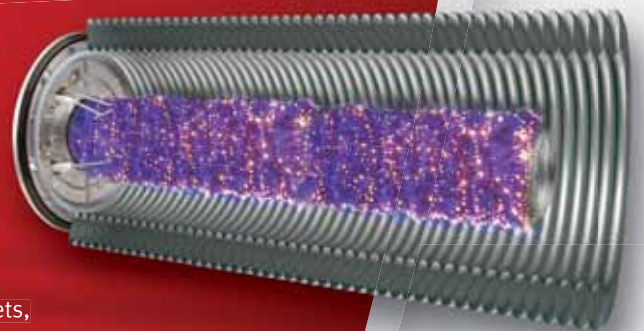

SMART

THE BRAIN THAT DRIVES BRILLIANT PERFORMANCE!

SMART SYSTEM provides unequalled control and monitoring functions that are easy to understand and use.

2-LINE, 16-CHARACTER LCD DISPLAY

Setup and diagnostic information in words, not codes

PASSWORD SECURITY

Dual password levels for installer and user

BUILDING MANAGEMENT SYSTEM CONTROL (0 – 10 V)

BMS-driven input for control of modulation rate or temperature

PC CONNECTION

Can be used with KNIGHT XL PC or Pocket PC software to program and troubleshoot SMART SYSTEM functions, and to track historical data, including faults, trends and energy consumption

OUTDOOR RESET

Outdoor temperature monitor guides the reset schedule to meet heat loss/load of the building

NIGHT SETBACK

Program a setback for any time of the day, each day of the week

SYSTEM PUMP AND BOILER PUMP CONTROLS

Provides power to both system and boiler pumps on a call for heat. Programmable pump delay orders pumps to operate after a call has been satisfied

PUMP RELAY WITH FREEZE PROTECTION

Ensures water temperature does not fall below 40°F

HOT WATER GENERATOR COMPATIBILITY

One boiler in a sequence can be assigned for Domestic Hot Water Prioritization (DHWP) to meet domestic water demand

INLET/OUTLET TEMPERATURE SENSORS AND DISPLAY

Installer can select which sensor controls the setpoint

LOW WATER FLOW INDICATOR

Protects against high temperature differential in the heat exchanger with reduced firing rate or shutdown

PRODUCT SERVICE INDICATOR

Program reminders for cycle count, operation hours or last service

FIELD CONNECTION VERSATILITY

User-friendly terminal strip allows for 28 low-voltage field connections. Plus 4 line voltage connections supply power to the unit, and up to 3 pumps operated by the SMART SYSTEM



15-1/2"

zero clearance
to combustibles

The 4-unit installation shown illustrates the space-saving KNIGHT XL footprint, and the ease and versatility of the two-pipe direct-vent design.

EASY HANDLING ON THE JOBSITE

Because of its compact design and stainless steel heat exchanger, KNIGHT XL boilers are remarkably lightweight and easy to handle on the jobsite.

DIRECT-VENTING UP TO 100 FEET

KNIGHT XL offers tremendous flexibility for placement of units within the building, because it permits direct-vent air intake and exhaust runs up to 100 equivalent feet using either PVC, CPVC or AL29-4C stainless steel vent pipe. Intake and exhaust runs can terminate horizontally through a sidewall or vertically through the roof.

EASY ACCESS TO INTERNAL COMPONENTS

The front and top panels of the KNIGHT XL boiler can be quickly removed without any tools. This provides fast, easy access to internal components and electrical connections during installation and service.



SYSTEMTM

INCLUDING A BUILT-IN CASCADING SEQUENCER!



In commercial buildings requiring a multiple boiler system, modulating operation of individual units should be sequenced so that the system functions as an integrated whole.

SMART SYSTEM includes a built-in cascading sequencer for up to 8 KNIGHT XL units. This eliminates the initial cost and labor required with installation of a separate sequencer. And, because it's engineered specifically for Lochinvar boilers, it removes any uncertainty about using a "third-party" sequencer, to ensure precise, dependable cascading operation.

When utilizing the built-in cascading sequencer, KNIGHT XL boilers communicate through a simple 2-wire daisy chain connection. On demand, one boiler in the system functions as the leader, and modulates with demand to capacity. The additional load then "cascades" to the second boiler, which fires and modulates to meet added demand.

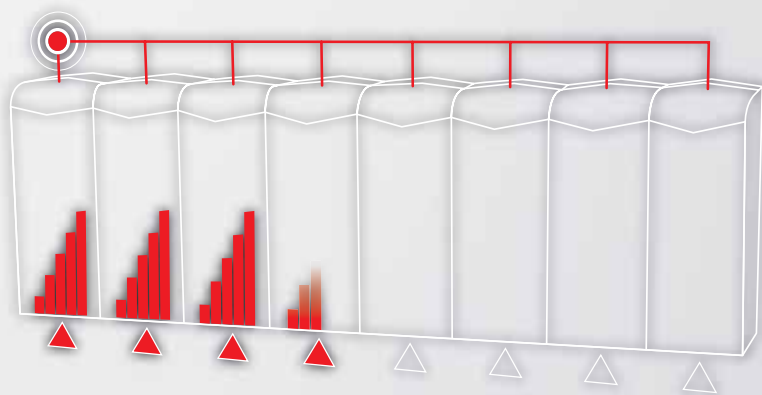

Cascading continues as additional boilers fire in sequence, until all units are in operation or demand is satisfied. When demand drops, the cascading process reverses, with the precision, control and performance you expect from Lochinvar.

SMART SYSTEM also controls Lead-Lag Rotation. Every 24 hours the lead boiler role is shifted to the next unit in the sequence. This rotation ensures long life by distributing "lead-lag" runtimes equally over each unit in the system.

KNIGHT® XL BOILER DIMENSIONS AND SPECIFICATIONS

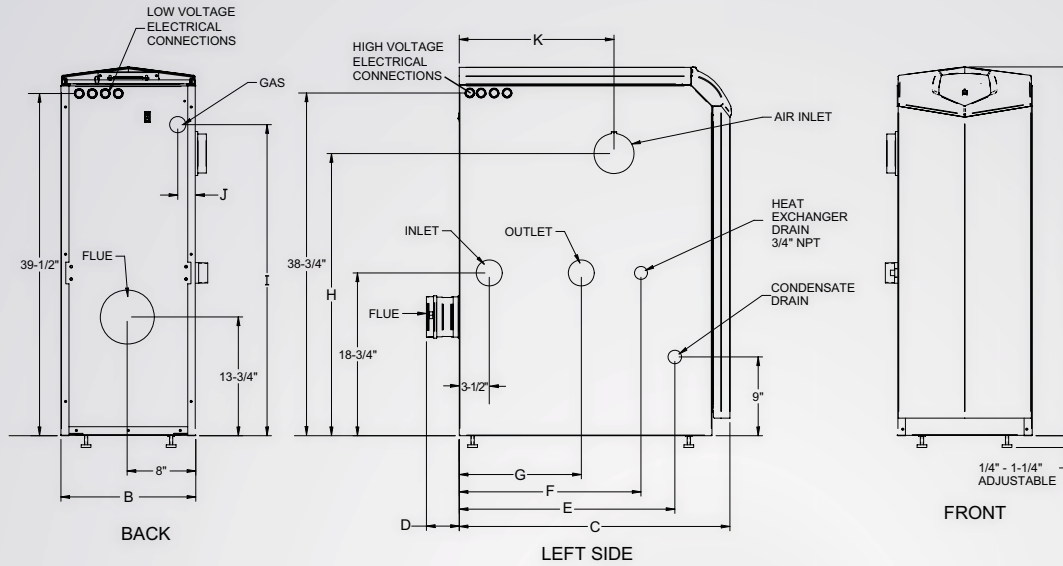

Model Number Guide

KB	N	700	M13
Model	Natural Gas	Btu/hr Input	Firing Controls

Knight XL Boiler,
Natural Gas,
700,000 Btu/hr input,
M13 firing controls

KNIGHT XL HEATING BOILER

DIMENSIONS AND SPECIFICATIONS

Model Number	Input		Thermal Efficiency %	Output MBH	NET I=B=R MBH	A	B	C	D	E	F	G	H	I	J	K	Gas Conn.	Water Conn.	Air Inlet	Vent Size	Shipping Wt. (lbs.)
	Min MBH	Max MBH				1"	15-1/2"	27"	3-3/4"	21"	20-3/4"	14"	34"	34"	2"	18-3/4"	1"	1-1/2"	4"	4"	285
KBN399	80	399	93.3	372	324	42-1/2"	15-1/2"	27"	3-3/4"	21"	20-3/4"	14"	34"	34"	2"	18-3/4"	1"	1-1/2"	4"	4"	285
KBN500	100	500	93.3	467	406	42-1/2"	15-1/2"	31-1/4"	3-3/4"	21"	25"	14"	35"	35"	2"	22"	1"	1-1/2"	4"	4"	305
KBN600	120	600	94.6	567	493	42-1/2"	15-1/2"	36-1/4"	3-3/4"	21"	25"	14"	36"	32-3/4"	5-1/2"	19-1/2"	1"	2"	4"	4"	355
KBN700	140	700	94.3	660	574	42-1/2"	15-1/2"	40-1/4"	3"	23"	29"	17"	36"	32-3/4"	3-1/4"	23-1/2"	1"	2"	4"	6"	395
KBN800	160	800	94.0	752	654	42-1/2"	15-1/2"	40-1/4"	3"	23"	33-1/4"	17"	36"	32-3/4"	3-1/4"	27-3/4"	1"	2"	4"	6"	440

Notes: Change 'N' to 'L' for L.P. Gas Model. No deration on L.P. models. Performance data based on manufacturer test results. 120 VAC /15 AMP circuit required. All dimensions shown in inches.

STANDARD FEATURES

- Up to 94.6% Thermal Efficiency
- Modulating Burner with 5:1 Turndown
- ASME Stainless Steel Heat Exchanger
- Direct-Vent Sealed Combustion
- PVC, CPVC or AL29-4C Venting up to 100 Feet
- SMART SYSTEM Digital Operating Control
- 50 psi Relief Valve
- Adjustable High Limit w/ Manual Reset
- Flow Switch
- Temperature & Pressure Gauge
- Direct-Spark Ignition
- Low NOx Operation
- Low Gas Pressure Operation
- Zero Clearances to Combustibles
- Easy Access Terminal Strip
- Natural to LP Conversion Kit
- Inlet & Outlet Temperature Sensors
- Outdoor Air Reset Sensor
- Low Water Flow Indication
- Domestic Hot Water Prioritization
- Adjustable Leveling Legs

- Sidewall Vent Terminals
- On/Off Switch
- Contact on Any Failure
- 10 Year Limited Warranty (See Warranty for Details)

OPTIONAL EQUIPMENT

- Alarm Bell on Any Failure
- Condensate Neutralization Kit
- High & Low Gas Pressure Switches w/ Manual Reset (KB500-KB800)
- Low Water Cutoff w/Manual Reset & Test
- SMART SYSTEM PC Software
- Stainless Steel Vent Kits

FIRING CODES

- M9 Standard Construction
- M7 California Code
- M13 CSD1/FM/GE Gap (KB500-KB800)

SMART SYSTEM FEATURES

- 2 LINE, 16-CHARACTER LCD DISPLAY
- PASSWORD SECURITY
- BUILT-IN CASCADING SEQUENCER
- BUILDING MANAGEMENT SYSTEM CONTROL
- 0-10 VDC INPUT CONTROL
- OUTDOOR RESET
- NIGHT SETBACK
- MULTIPLE PUMP CONTROL (SYSTEM, BOILER & DHW)
- PUMP RELAY WITH FREEZE PROTECTION
- PRODUCT SERVICE INDICATOR
- FIELD CONNECTION VERSATILITY
- OPTIONAL PC OR POCKET PC SOFTWARE



Lochinvar®
High Efficiency Water Heaters, Boilers and Pool Heaters