

Glass-Lined, Jacketed & Insulated or Bare ASME Tanks

Lock-Temp[®] Storage Tanks

Lock-Temp Design Locks Hot Water at Top, Cold Water at Bottom.

Lochinvar Lock-Temp Tanks have been specifically designed and engineered to provide a high volume supply of hot water at a constant outlet temperature. The unique Lock-Temp baffle chamber design is so efficient that, regardless of the rate of hot water flow, 80% of the stored volume of hot water can be drawn from the storage tank without a drop in the pre-set outlet temperature.

Since 1/3 less hot water storage is required with Lock-Temp Storage Tanks than with ordinary storage tanks, there are several important economic features to consider: **Lower Standby Losses, Smaller Footprint Required, Lower Installed Cost, Reduced Water Heater Operation Cost.**

In operation, Lock-Temp Storage Tanks utilize a unique water baffle chamber to eliminate turbulence and establish a positive, piston-like displacement system. Cold water entering the system is directed into the built-in baffle chamber, where water turbulence is eliminated. Eliminating turbulence allows natural physical properties to force hot water to the top of the tank and cold water to the bottom. The resulting effect creates nearly perfect stratification allowing the hot water to be drawn from the tank first.

The Lock-Temp system makes Lochinvar Storage Tanks more efficient. Consider that a typical storage tank delivers only about 60% of its stored water volume at the desired temperature while Lochinvar tanks with the Lock-Temp baffle deliver a minimum of 80%. This efficiency allows for more economical sizing of storage tanks. A design calling for 400 gallons of 180°F water would require a 670 gallon standard tank while a Lock-Temp tank would deliver the same 180°F volume using only a 500 gallon tank. A 170 gallon savings.

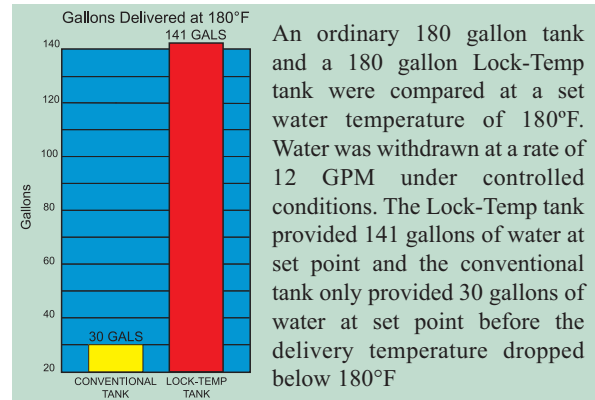

Advantages of a Lock-Temp storage tank over conventional storage tank

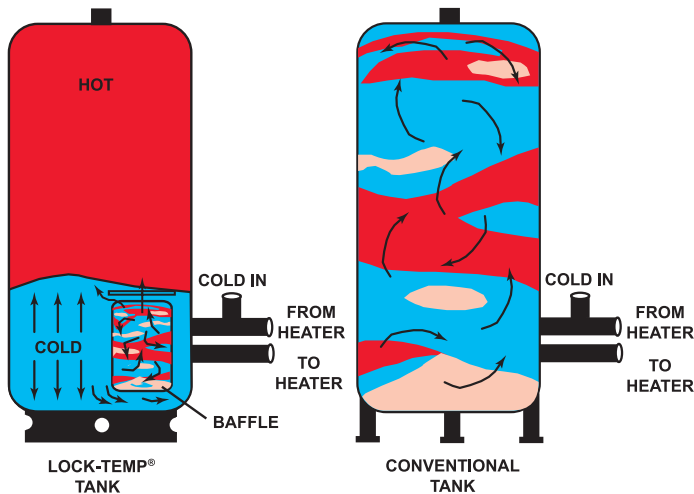

In ordinary storage tanks, water circulation or a heavy draw of hot water from the top of the tank causes an incoming rush of cold water, creating turbulence in the tank's stored water supply. The result is inter-mixed hot and cold water that requires constant adjustment at the fixtures to maintain the desired temperature. Lochinvar Lock-Temp Storage Tanks eliminate these problems with a unique inner chamber baffle that absorbs and flattens turbulence caused by incoming water. The Lock-Temp baffle also permits hot and cold water to stratify, directing the hottest water to the top of the tank and the colder water to the bottom for return to the heater.

World Class Tank Manufacturing



1 CNC Laser Cutting Control Panel

To provide the greatest accuracy the CNC laser cutting machine uses PLC controls. All programming is performed in-house and stored in the shop computers.



2 Hydraulic Plate Roll

The plate roll turns a flat plate of steel (up to 1/2" thick) into a round cylinder.



3 Submerged Arc Longitudinal Seam Welder

As the welding head travels 28-30 IPM, the welding wire penetrates the steel to form a full-penetration weld on both the inner and outer surface of the tank shell.



4 Fit-Up Weld

Tank heads and fittings are tacked and welded into the tank shell by ASME certified welders.

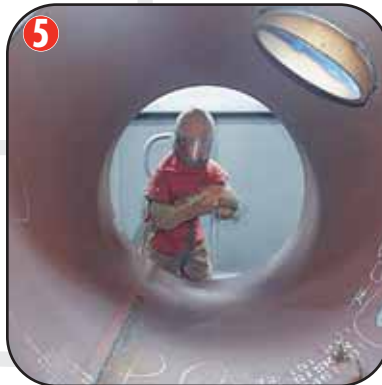

5 Internal Shot Blasting

All internal surfaces are blasted to a white metal, removing rust, scale, greases and oils so lining can have optimum adhesion.



6 Submerged Arc Circumferential Welder

Here the submerged arc welding process welds the ends on as the tank rotates. A full-penetration X-ray quality weld is made in two to four passes.



7 4.5 Million BTU Intermittent Glass Furnace

After a drying process, the tanks enter the furnace module. The glass lining is fired at 1600° F to create a molecular bond between the glass frit and the vessel's steel surface. This is the largest indexing furnace in the United States.



8 Hydrostatic Testing

Upon completion of the manufacturing processes, each tank has all threaded openings tapped and cleaned. The tanks are then filled with water and brought up to the designed working pressure.



9 Lasting Quality

The ASME inspector then administers tests for leaks and other nonconformances. Magnesium anode rods are provided with each glass tank to protect the integrity of the lining.

Dimensions and Specifications for Vertical Tanks

Vertical Round Jacketed Glass Lined Tanks

Model Number	Gal. Cap.	A	B	D	E	Shipping Weight	
						125 psi	150 psi
RJS080	78	58-3/4"	24"	9-1/4"	14-1/4"	-	192
RJS120	119	62-1/2"	28"	9-1/2"	14-1/2"	-	345
RJA120	119	62-1/2"	28"	9-1/2"	14-1/2"	-	365
RJA175	175	67-1/4"	32"	11-1/4"	17-1/4"	-	525
RJA200	200	77-1/4"	32"	11-1/4"	17-1/4"	-	600

* Indicates tank lining.

G=Glass Lined

C=Cement

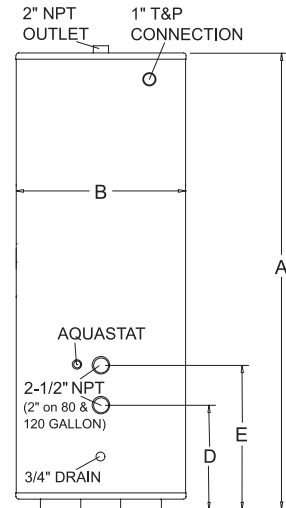

Vertical Round Jacketed ASME Tanks

Model Number	Gal. Cap.	A	B	D	E	Shipping Weight	
						125 psi	150 psi
R*A0257	257	91"	34"	18"	26"	1,108	1,108
R*A0318	318	80"	40"	19-1/2"	27-1/2"	1,290	1,290
R*A0432	432	80"	46"	21"	29"	1,512	1,626
R*A0504	504	92"	46"	21"	29"	1,623	1,765
R*A0650	650	92"	52"	23-1/2"	31-1/2"	1,911	1,911
R*A0752	752	104"	52"	23-1/2"	31-1/2"	2,330	2,330
R*A0940	940	128"	52"	23-1/2"	31-1/2"	3,010	3,010

* Indicates tank lining.

G=Glass Lined

C=Cement

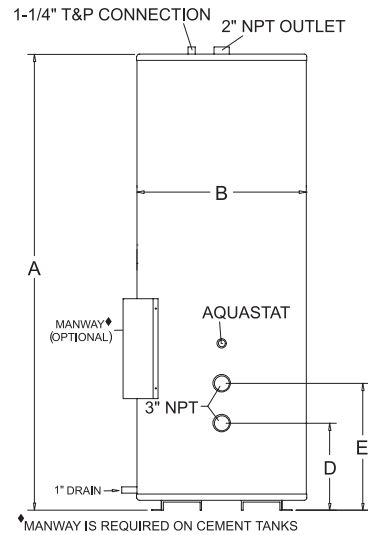

Vertical Square Jacketed ASME Tanks

Model Number	Gal. Cap.	A	B	D	E	Shipping Weight	
						125 psi	150 psi
TV*1250J	1250	132-1/2"	64-1/2"	29-1/4"	21-1/4"	4,660	5,000
TV*1500J	1500	128 1/2"	70-1/2"	31-3/4"	25-3/4"	6,200	6,637
TV*2000J	2000	140-1/2"	76-1/2"	33-1/2"	25-1/2"	7,400	7,910
TV*2500J	2500	146-1/2"	82-1/2"	35-1/4"	28"	9,000	9,632

* Indicates tank lining.

G=Glass Lined

C=Cement

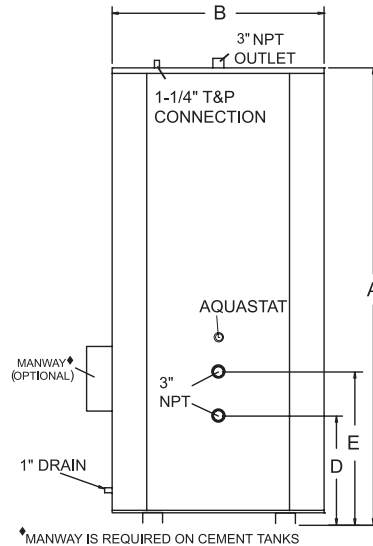

Dimensions and Specifications for Horizontal Tanks

Horizontal Round Jacketed ASME Tanks

Model Number	Gallon Capacity	Dimensions			Shipping Weight	
		A	B	Diameter	125 psi	150 psi
R*A0250H	250	41"	88"	34"	1,157	1,157
R*A0300H	300	47"	76"	40"	1,355	1,355
R*A0400H	400	53"	76"	46"	1,587	1,701
R*A0500H	500	53"	88"	46"	1,711	1,853
R*A0600H	600	59"	88"	52"	2,053	2,053
R*A0700H	700	59"	100"	52"	2,399	2,399
R*A1000H	1000	59"	124"	52"	3,114	3,114

*Indicates Tank Linings

G=Glass Lined

C=Cement

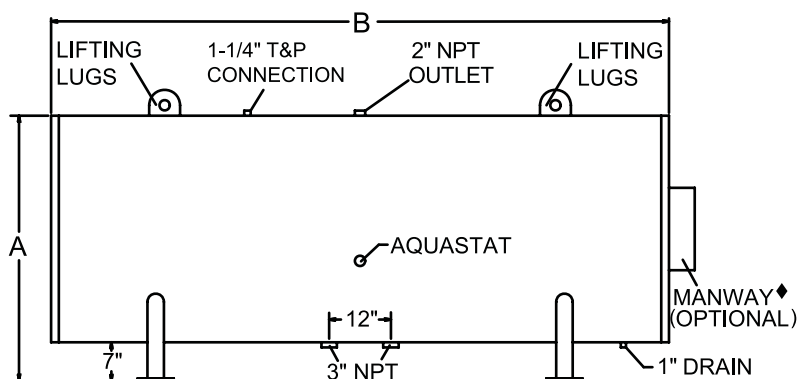

♦MANWAY IS REQUIRED ON CEMENT TANKS

Horizontal Square Jacketed ASME Tanks

Model Number	Gallon Capacity	Dimensions			Shipping Weight	
		A	B	Depth	125 psi	150 psi
TH*1250J	1250	68-1/2"	130-1/4"	60-1/4"	5,126	5,466
TH*1500J	1500	77 1/2"	126-1/4"	66-1/4"	6,820	7,257
TH*2000J	2000	80-1/2"	138-1/4"	72-1/4"	8,140	8,650
TH*2500J	2500	86-1/2"	144-1/4"	78-1/4"	9,900	10,532

*Indicates Tank Linings

G=Glass Lined

C=Cement

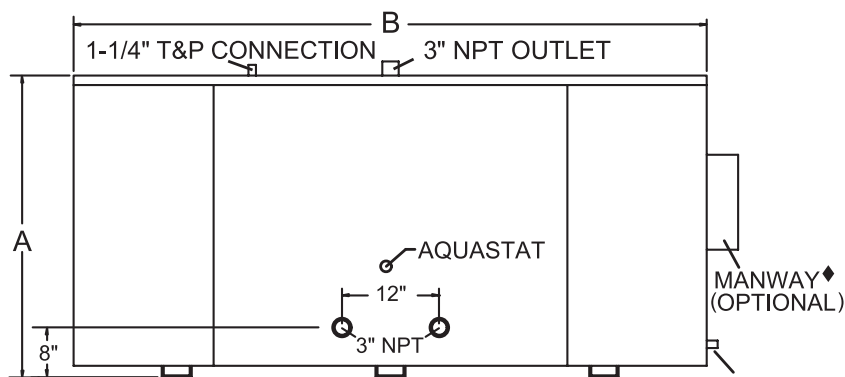

♦MANWAY IS REQUIRED ON CEMENT TANKS

Dimensions and Specifications for Bare Tanks Vertical/Horizontal

Gal. Cap.	Dimensions			Weights			Tappings		
	D Dia.	V Ht.	H Lgth.	Glass-Lined 125 psi	Cement Lined 150 psi	Cement Lined	A	B	C
118	24"	64"	60"	368	368	-	13-1/2"	21-1/2"	29-1/2"
141	24"	76"	72"	428	428	-	13-1/2"	21-1/2"	29-1/2"
188	24"	100"	96"	556	556	-	13-1/2"	21-1/2"	29-1/2"
235	24"	124"	120"	684	684	-	13-1/2"	21-1/2"	29-1/2"
200	28"	76"	-	-	488	-	11"	17-1/2"	16"
147	30"	52"	48"	400	400	695	15-3/4"	23-3/4"	31-3/4"
184	30"	64"	60"	468	468	812	15-3/4"	23-3/4"	31-3/4"
220	30"	76"	72"	548	548	958	15-3/4"	23-3/4"	31-3/4"
257	30"	87"	83"	628	628	1,103	15-3/4"	23-3/4"	31-3/4"
294	30"	100"	96"	701	701	1,242	15-3/4"	23-3/4"	31-3/4"
367	30"	124"	120"	868	868	1,540	15-3/4"	23-3/4"	31-3/4"
265	36"	64"	60"	577	577	995	17-1/2"	25-1/2"	33-1/2"
318	36"	76"	72"	673	673	1,173	17-1/2"	25-1/2"	33-1/2"
370	36"	87"	83"	770	770	1,343	17-1/2"	25-1/2"	33-1/2"
423	36"	100"	96"	866	866	1,513	17-1/2"	25-1/2"	33-1/2"
528	36"	124"	120"	1,058	1,058	1,861	17-1/2"	25-1/2"	33-1/2"
432	42"	76"	72"	795	909	1,385	18-3/4"	26-3/4"	34-3/4"
504	42"	88"	84"	908	1,050	1,587	18-3/4"	26-3/4"	34-3/4"
576	42"	100"	96"	1,020	1,190	1,790	18-3/4"	26-3/4"	34-3/4"
720	42"	124"	120"	1,245	1,470	2,195	18-3/4"	26-3/4"	34-3/4"
864	42"	148"	144"	1,470	1,751	2,601	18-3/4"	26-3/4"	34-3/4"
1,008	42"	172"	168"	1,695	2,031	3,006	18-3/4"	26-3/4"	34-3/4"
658	48"	88"	84"	1,346	1,346	2,124	20-3/4"	28-3/4"	36-3/4"
752	48"	100"	96"	1,507	1,507	2,392	20-3/4"	28-3/4"	36-3/4"
940	48"	124"	120"	1,828	1,828	2,918	20-3/4"	28-3/4"	36-3/4"
1,128	48"	148"	144"	2,150	2,150	3,444	20-3/4"	28-3/4"	36-3/4"
1,315	48"	172"	168"	2,471	2,471	3,970	20-3/4"	28-3/4"	36-3/4"
1,503	48"	196"	192"	2,793	2,793	4,505	20-3/4"	28-3/4"	36-3/4"
951	54"	100"	96"	1,721	1,972	2,729	22-3/4"	30-3/4"	38-3/4"
1,189	54"	124"	120"	2,083	2,423	3,320	22-3/4"	30-3/4"	38-3/4"
1,427	54"	148"	144"	2,451	2,881	3,919	22-3/4"	30-3/4"	38-3/4"
1,665	54"	172"	168"	2,807	3,326	4,511	22-3/4"	30-3/4"	38-3/4"
1,903	54"	196"	192"	3,168	3,777	5,102	22-3/4"	30-3/4"	38-3/4"
2,141	54"	220"	216"	3,530	4,228	5,701	22-3/4"	30-3/4"	38-3/4"
1,469	60"	124"	120"	2,784	3,221	4,177	24-3/4"	32-3/4"	40-3/4"
1,763	60"	148"	144"	3,267	3,823	4,913	24-3/4"	32-3/4"	40-3/4"
2,056	60"	172"	168"	3,749	4,425	5,658	24-3/4"	32-3/4"	40-3/4"
2,350	60"	196"	192"	4,231	5,026	6,394	24-3/4"	32-3/4"	40-3/4"
2,644	60"	220"	216"	4,713	5,628	7,130	24-3/4"	32-3/4"	40-3/4"
2,115	72"	124"	120"	3,416	3,904	5,104	27-3/4"	35-3/4"	43-3/4"
2,538	72"	148"	144"	3,995	4,627	5,995	27-3/4"	35-3/4"	43-3/4"
2,961	72"	168"	168"	4,575	5,350	6,885	27-3/4"	35-3/4"	43-3/4"
3,384	72"	196"	192"	5,154	6,073	7,767	27-3/4"	35-3/4"	43-3/4"
3,807	72"	220"	216"	5,733	6,795	8,658	27-3/4"	35-3/4"	43-3/4"

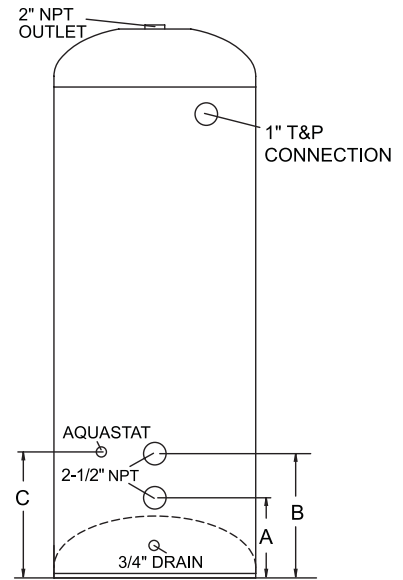

24" & 28" DIAMETER TANKS

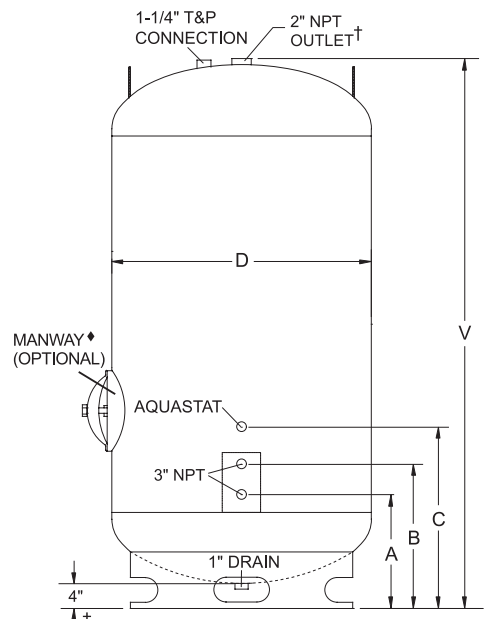

30" DIAMETER AND LARGER TANKS

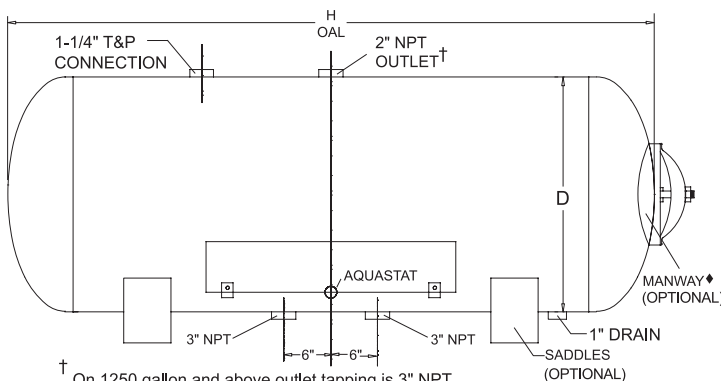

† On 1250 gallon and above outlet tapping is 3" NPT
 ♦ Manway is required on cement lined tanks

Tank Saddle Dimensions

TANK DIAMETER							
24	30	36	42	48	54	60	72
A	18"	21"	25"	29"	34"	48"	62"

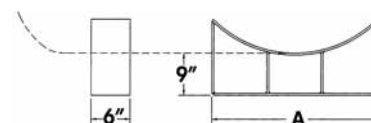

NOTE: Alternate saddle heights are available. (Consult factory)

Glass-Lined Tank



Lochinvar's glass lining is a specially formulated vitreous porcelain enamel lining, which is applied to all interior surfaces of the tank. After the tank surfaces are cleaned to a white metal

finish, an automated spraying process applies a uniform glass lining. The lining is continuously monitored for thickness and continuity. The tank is then fired to 1600°F to assure molecular fusing of the glass to the interior steel surfaces and each glass lined

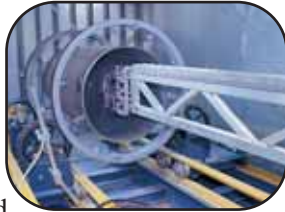

tank is tested for glass conformance prior to final assembly. Upon completion of the lining process, each tank is hydro tested per the ASME standard. The combination of high quality materials, rigorous



metal preparation, and careful testing results in the best possible coating for potable water in a storage vessel.

Cement Lined Tanks

Cement lined tanks have approximately the same coefficient of expansion as mild steel, it poses no cracking potential due to internal pressures. The lining is applied in two coats; first approximately 1/4" thick to provide a firm base for the second coat. After the tank is completely lined, it is allowed to set for 12-20 hours immersed in water, then drained, and flushed. This cement lining provides an excellent coating to give protection to the tanks steel base metal against corrosion in a potable water storage vessel.



Tank Outstanding Features

- **Energy Saving Performance -**

Jacketed tanks meet the efficiency requirements of the latest ASHRAE Energy Efficiency Standards. The 2" of R16 foam insulation provides low standby energy loss for optimum performance and economy.

Note: Bare tanks must be field insulated to meet ASHRAE stand-by loss requirements



- **Five-Year Limited Warranty -** Provides warranty protection against tank failure resulting from defects in materials or workmanship.

- **Lock-Temp Baffle -** Lock-Temp

storage tank baffles eliminate turbulence and establish a piston-like displacement system which creates nearly perfect stratification.



- **Magnesium Anode -** All glass-lined tanks are equipped with one or more magnesium anodes to provide additional protection against corrosion.

- **ASME Construction -** All models constructed in accordance with ASME standards and labeled for 125 psi working pressure (standard) or 150 psi working pressure (optional).



- **Manway -** A manway inspection port is provided as standard equipment on Cement lined tanks. Manway is optional on glass-lined tanks 30" diameter & larger.

- **Galvanized Jacket -** Heavy gauge jacket is galvanized on both sides and finished in durable acrylic enamel combining attractive appearance with maximum protection.

- **Square Jacketed Models -** Built-in Safety Drain Pan System, and a sealed base assembly mounted on Channel Iron Skids with a 3/4" drain connection.



Lochinvar[®]
High Efficiency Water Heaters, Boilers and Pool Heaters



Lochinvar Corporation • 300 Maddox Simpson Pkwy • Lebanon, TN 37090 • 615-889-8900 / Fax: 615-547-1000